

# WEBINARS PHOTONICS MEDIA [photonics.com](http://photonics.com)

Expand your knowledge. Grow your career.



Join us for a **FREE Webinar**

## Ray Optics Simulations

**Thursday, June 4, 2020 2:00 PM - 3:00 PM EDT**

[Register Now](#)

Presented by



### About This Webinar

Tune into this webinar to learn about optical ray tracing using the COMSOL Multiphysics® software.

This presentation will include a live demo in the software, showing how to create a fully parameterized geometry of a typical lens system; trace rays through the system; and postprocess the results. The webinar will also discuss more specialized ray features, such as the analysis of ray intensity and polarization. Presenter Chris Boucher will explain how the Ray Optics Module, an add-on product to COMSOL Multiphysics®, can be combined with structural and thermal simulation for highly accurate structural-thermal-optical performance (STOP) analysis. Attendees can ask questions throughout the webinar or at the end during the Q&A session.

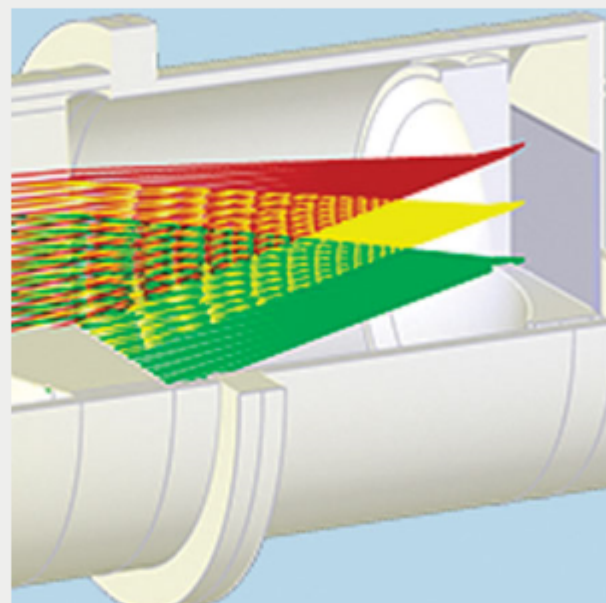

#### Who should attend:

Engineers and researchers who:

- Design or use devices such as laser focusing systems, spectrometers, cameras, and telescopes.
- Manipulate light with prisms, lenses, beamsplitters, or gratings.
- Design devices to redirect and focus solar radiation.
- Must consider thermal or structural phenomena and their effects on optical performance.

#### Attendees will learn:

- How to set up a fully parameterized system of lenses using the geometry tools in COMSOL Multiphysics®.
- How to trace rays through a lens system using the Ray Optics Module.
- How to store information about intensity, polarization, phase, number of reflections, and optical path length along rays as part of a simulation.
- How COMSOL Multiphysics® facilitates coupled STOP analysis.
- How to use built-in evaluation tools to analyze and report simulation results.

#### About the presenter:

Chris Boucher is the technical product manager for the COMSOL Particle Tracing Module and Ray Optics Module. He received his B.S. in aerospace engineering and physics from Worcester Polytechnic Institute (WPI) before joining COMSOL in 2012.

#### About COMSOL:

COMSOL is a global provider of software solutions for multiphysics modeling. Its COMSOL Multiphysics® product is an integrated software environment for creating physics-based models and simulation apps. Add-on products expand the simulation platform for electrical, mechanical, fluid flow, and chemical applications. Interfacing tools enable the integration of COMSOL Multiphysics® simulations with all major technical computing and CAD tools on the CAE market. Simulation experts rely on the COMSOL Server™ product to deploy apps to their design teams, manufacturing departments, test laboratories, and customers throughout the world.

Please see [www.comsol.com/privacy](http://www.comsol.com/privacy) for COMSOL's Privacy Policy. Contact COMSOL at [www.comsol.com/contact](http://www.comsol.com/contact) for more information. Note that COMSOL will follow up with all registrants about this event and any related questions.

### Mark Your Calendar

**Date: Thursday, June 4, 2020**

**Time: 2:00 PM - 3:00 PM EDT**

Space is limited. Reserve your Webinar seat now at: <https://attendee.gotowebinar.com/register/5056365210072947211>

After registering you will receive a confirmation email containing information about joining the Webinar.

### SYSTEM REQUIREMENTS

#### PC-based attendees

Required: Windows® 10, 8, 7, Vista, XP or 2003 Server

#### Mac® -based attendees

Required: Mac OS® X 10.6 or newer

#### Mobile attendees

Required: iPhone®, iPad®, Android™ phone or tablet, Windows 8 or Windows Phone 8

### More from Photonics Media

#### Upcoming Webinars

- Simplifying AI in Machine Vision with IDS NXT Ocean, 5/26/2020 1:00:00 PM EDT
- Upgrade Your Fiber Optic Diagnostics with Portable Ultra-High Resolution Optical Backscatter Reflectometry, 6/2/2020 1:00:00 PM EDT
- A New Approach to Interferometry: Unlocking New Possibilities in UV/VIS Spectroscopy, 6/17/2020 10:00:00 AM EDT

#### Archived Webinars

- Squeezing More Out of Light: Innovative Approaches to Time-Resolved Flow Cytometry
- Ellipsometry: What Is It and What Can It Do for You?
- Raman Spectroscopy: Theory, Practice, and Applications

We respect your time and privacy. You are receiving this email because you are a Photonics Media subscriber, and/or a member of our website, Photonics.com. You may use the links below to manage your subscriptions or contact us.

Questions: [info@photonics.com](mailto:info@photonics.com)

[Unsubscribe](#) | [Subscribe](#) | [Subscriptions](#) | [Privacy Policy](#) | [Terms and Conditions of Use](#)

Photonics Media, 100 West St., PO Box 4949, Pittsfield, MA 01202-4949

© 1996 - 2020 Laurin Publishing. All rights reserved. Photonics.com is Registered with the U.S. Patent & Trademark Office. Reproduction in whole or in part without permission is prohibited.